

# 6CH 2A Leading Edge Dimming Actuator

## Datasheet



HDL-MD0602.532



Please scan the QR code above to check the latest version of datasheet!

Before using this product, please read this datasheet carefully and keep it properly!

Document Version: C

## ◆◆ Overview

6CH 2A Leading Edge Dimming Actuator (hereinafter referred to as the “product” or “device”) is compatible with 220V AC and 110V AC power input, which supports six output channels. For each channel, it is respectively equipped with fuse, bypass button and indicators to protect the product against short circuit.

Note: The pictures and illustrations provided in this instruction manual are for reference purposes only, and the actual product may differ.

### Key Functions:

1. Up to 6 separate zones; Up to 12 scenes for each zone
2. Up to 6 sequences ; 12 steps for each sequence
3. Low, high and maximum threshold for each channel
4. 4A fuse of each channel for protection (aR type)
5. Auto status recall of scenes or designated scenes after reboot
6. 4 dimming curves with 512 dimming accuracy
7. Short circuit protection , overheat protection
8. Online update

## ◆◆ Technical Data

<b>Rated voltage</b>	<b>15 - 30V DC</b>
Rated current	28mA / 24V DC
Input voltage	100 - 240V AC, 50/60Hz
Output channel	6CH, 2A/CH
Communication protocol	Buspro
Maximum output current in total	10A
Fuse	4A, aR type
Dimming mode	Leading edge dimming control , minimum load 40W
Dimming curve	Linear, 1.5 exponent, 2.0 exponent, 3.0 exponent
Working temperature	-5°C ~ 45°C
Working relative humidity	≤90%RH, non-condensed
Storage temperature	-20°C ~ 60°C
Storage relative humidity	≤93%RH

## ◆◆ Specifications

<b>Dimensions (W X H X D)</b>	<b>144×90×64mm (See Figure 2 &amp; 3)</b>
Net weight	813g
Housing material	Nylon, PC
Installation	35mm DIN rail mounted (See Figure 5 & 6)
IP degree (compliant with EN 60529)	IP20
Approved	CE

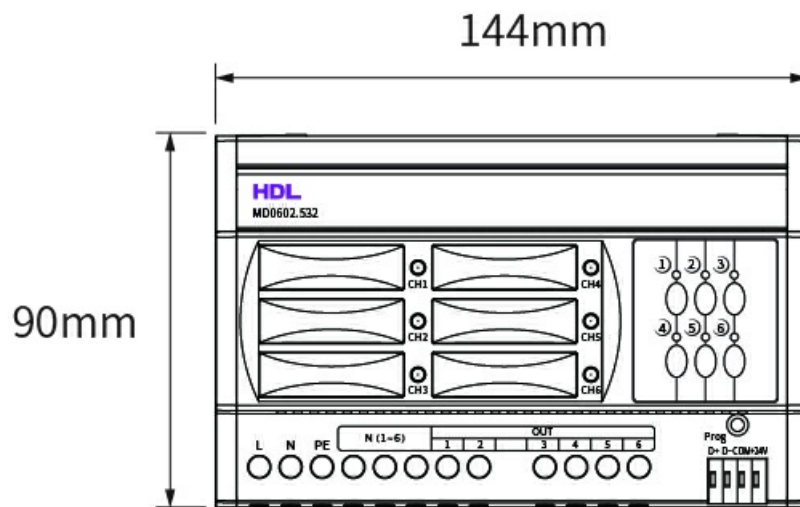

Figure 2

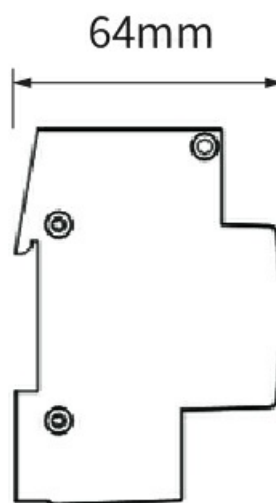

Figure 3

## ◆◆ Safety Precaution

### Danger:

Please do not privately disassemble or replace any parts of the product. Otherwise, it may cause mechanical fault, electric shock, fire or personal injuries.

### Warning:

- The installation and testing for the product must be carried out by HDL Automation Co., Ltd. (hereinafter referred to as HDL) or its appointed service agencies. The electric construction shall comply with local laws and safety regulations.
- The device should be installed with DIN rail in DB box. HDL will not be responsible for any consequence caused by the inexpert or faulty installation and wiring methods, which are not in accordance with the instructions contained in this datasheet.
- Please contact HDL after-sales departments or our designated service agencies for your maintenance service. Product failures caused by private disassembly are not subject to the warranty.

### Caution:

- Before performing any installation or disassembly procedures on the device, it is crucial to disconnect the device from all voltage sources. This step is necessary to ensure the safety of the technician and prevent any potential damage to the device.
- Do not use corrosive liquid to wipe the device body, especially the interface, so to avoid damage to the device.
- Do not wipe the device with a damp cloth.
- Before performing any maintenance or cleaning procedures on the device, it is imperative to disconnect the device from all voltage sources. This precautionary measure is necessary in order to prevent electric leakage and the risk of electric shock.
- Buspro cable: CAT5E or HDL Buspro cable
- For Buspro connection, a hand-in-hand connection is recommended.
- After all of the cables are terminated, check for correct and good terminations.
- Protective earthing (PE) is required.
- Please note to select the power input via the debugging software, 220V AC or 110V AC.
- Prior to replacing the fuse, disconnect the device from all voltage sources. The new fuse should be aR type.
- Load types supported include incandescent light, halogen light, low-voltage halogen light, LED light, etc. All loads must be suitable for leading edge dimming.
- The ambient temperature should be below 50°C for the device to work properly.
- Overrange is not allowed. Please use the device in accordance with the technical specifications.

## ◆◆ Wiring

Tips:

- For Buspro connection, a hand-in-hand connection is recommended.
- Protective earthing (PE) is required.
- Please note to select the power input via the debugging software, 220V AC or 110V AC.
- After all of the cables are terminated, check for correct and good terminations.

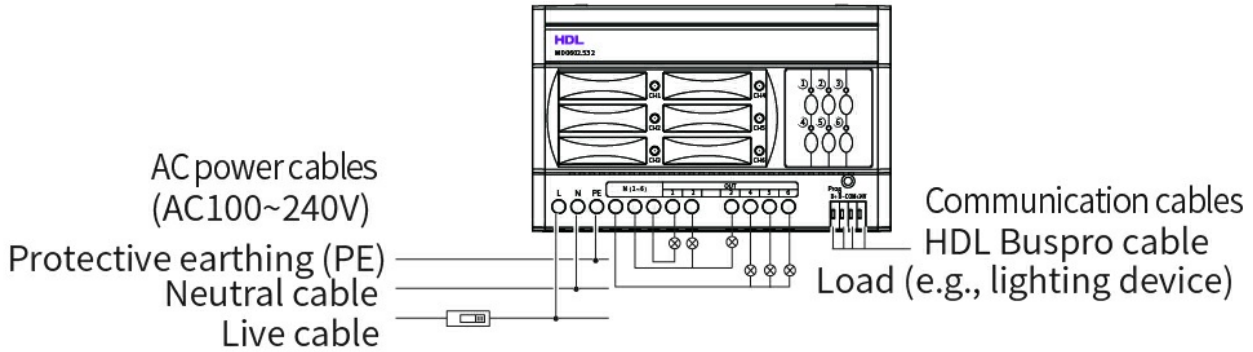

Figure 4

HDL Buspro Cable Guide:

HDL Buspro	HDL Buspro Cable	CAT5 / CAT5E
DATA+	Yellow	Blue/Green
DATA-	White	Blue white/Green white
COM	Black	Brown white/Orange white
24V DC	Red	Brown/Orange

- 

## ◆◆ Installation

Warning: Before performing any installation procedures on the device, it is crucial to disconnect the device from all voltage sources.

Step 1. Fix the DIN rail with screws.

Step 2. Mount the device on the DIN rail.

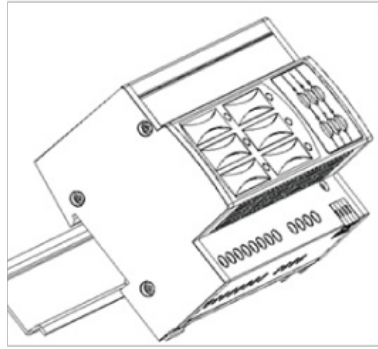

Figure 5

Step 3. Slide the device to the desired position.

Note: After all of the cables are terminated, check for correct and good terminations. Before powering on, please ensure the device is tightly on the wall body.

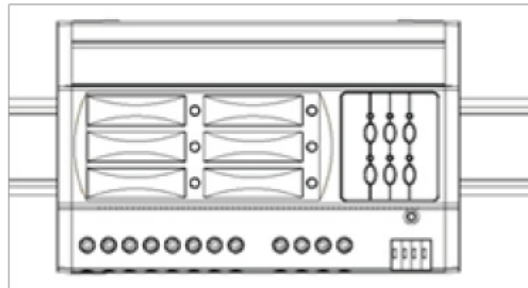
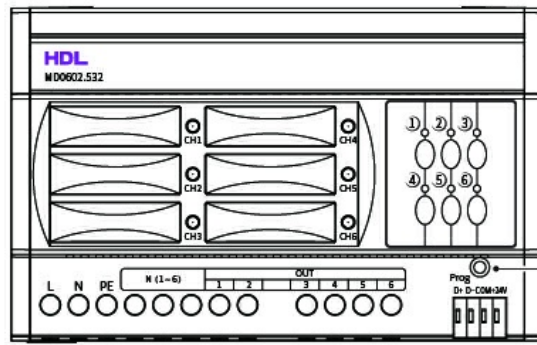

Figure 6

## ◆◆ Operation

The device is configured with one programming button.



Programming button  
(built-in indicator)

Figure 7

Operation	Result / Device Status
/	When the device runs normally, the indicator flashes.
When the device runs normally, press the programming button for about 3s.	The device ID can be read and modified via the debugging software.

## ◆◆ Packing List

- 6CH 2A Leading Edge Dimming Actuator\*1
- Terminal block\*1
- Fuse\*1

Note: After unpacking, please check if the product and the parts are complete.

## ◆◆ Copyright Statement

HDL has all the intellectual property rights to this document and contents thereof. Reproduction or distribution for third parties are prohibited without written authorization from HDL. Any infringement of HDL's intellectual property rights will be investigated the legal liability.

The contents of this document will be updated as the updates of product versions or other reasons. Unless otherwise agreed upon, this document is to be used as a guidance only. All the statements, information and recommendations in this document makes no warranty expressed or implied.

## Update History:

The form below contains the information of every update. The latest version contains all the updates of all former versions.

Version	Update Information	Date
V1.0	Initial release	October 31, 2025

## ◆◆ Technical Support

E-mail: [hdtickets@hdlautomation.com](mailto:hdtickets@hdlautomation.com)

Website: <https://www.hdlautomation.com>

## ◆◆ Troubleshooting

E-mail: [hdtickets@hdlautomation.com](mailto:hdtickets@hdlautomation.com)

Website: <https://www.hdlautomation.com>